

# Diode Pumped Sub-Nanosecond Actively Q-Switched Laser

## MPL15100

### FEATURES

- › More than **0.5 mJ** pulse energy at **1064 nm**
- › Short pulse duration **< 700 ps**
- › Up to **1 kHz** repetition rate
- › **532 nm, 355 nm, 266 nm** wavelengths as standard option
- › Actively Q-Switched
- › Peak Power **0.7 MW**
- › Other wavelengths (e.g. 532 nm, 355 nm, 266 nm) are available

### APPLICATIONS

- › Spectroscopy
- › Marking
- › MALDI
- › Seeding laser amplifiers
- › Pollution Monitoring
- › Remote sensing

**MPL15100** series robust DPSS actively Q-switched sub-nanosecond lasers deliver multi-kW peak powers, less than 1 ns pulse duration at 1 kHz repetition rate. Short innovative laser cavity with is fixed on thermo-stabilized baseplate which gives extremely stable output parameters performance. Small footprint is welcome point for integration into OEM lasers. Sub-nanosecond pulse duration of < 700 ps with near transform limited spectral linewidth at repetition rates up to 1 kHz with low timing jitter of < 200 ps and energies more than 500  $\mu$ J covers broad spectrum of applications starting from LIBS, laser induced fluorescence to many others. Standard optional harmonics generator to green (532 nm) and ultraviolet (355 nm, 266 nm) is also available.



# Specifications <sup>1)</sup>

MODEL	MPL15100	MPL15100-1K
Pulse energy:		
at 1064 nm	0.5 mJ	
at 532 nm	0.25 mJ	
at 355 nm	0.15 mJ	
at 266 nm	0.1 mJ	
Typical pulse duration	< 700 ps <sup>2)</sup>	
Pulse to pulse energy stability (RMS):		
at 1064 nm	< 0.5 % <sup>3)</sup>	
at 532 nm	< 1.0 % <sup>3)</sup>	
at 355 nm	< 1.5 % <sup>3)</sup>	
at 266 nm	< 2.0 % <sup>3)</sup>	
Power drift	± 3.0 % <sup>4)</sup>	
Pulse repetition rate <sup>5)</sup>	100 Hz	1 kHz
Beam spatial profile	Close to Gaussian	
Beam divergence <sup>6)</sup>	< 4 mrad	
Polarization	Linear, horizontal at 1064 nm	
Spectral linewidth	SLM	
Beam pointing stability <sup>7)</sup>	< 50 µrad	
Typical beam diameter <sup>8)</sup>	1.2 mm	
Optical jitter	< 0.2 ns <sup>9)</sup>	

## DIMENSIONS

Laser head (W×L×H)	163 × 295 × 53.5 mm	
Controller unit (W×L×H)	257 × 271 × 153 mm	
Cable cord length	1 m	

## OPERATING REQUIREMENTS

Cooling requirements	air cooled	
Ambient temperature	15 – 30 °C	
Relative humidity	10 – 80 % (non-condensing)	
Mains voltage	100 – 240 VAC, single phase, 50 – 60 Hz	
Power consumption	< 10 W	< 100 W

<sup>1)</sup> Due to continuous improvements all specifications are subject to change. Unless stated otherwise all specifications are measured at 1064 nm.

<sup>2)</sup> FWHM level at 1064 nm.

<sup>3)</sup> Averaged from 60 seconds time interval.

<sup>4)</sup> Over 8-hour period after max 5 minutes of warm-up when ambient temperature variation is less than ±2 °C.

<sup>5)</sup> Factory-set pulse repetition rate is fixed at max repetition rate. Higher repetition rates are available, please inquire for details.

<sup>6)</sup> Full angle measured at the 1/e<sup>2</sup> level.

<sup>7)</sup> RMS value measured from 1000 shots.

<sup>8)</sup> Beam diameter is measured 20 cm from laser output at the 1/e<sup>2</sup> level.

<sup>9)</sup> In respect to Q-switch triggering rising edge pulse.

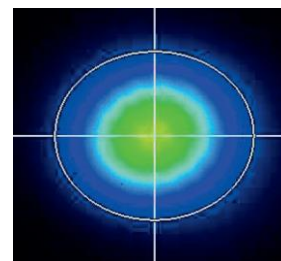

Typical beam intensity profile (20 cm from laser output) of MPL15100 series lasers

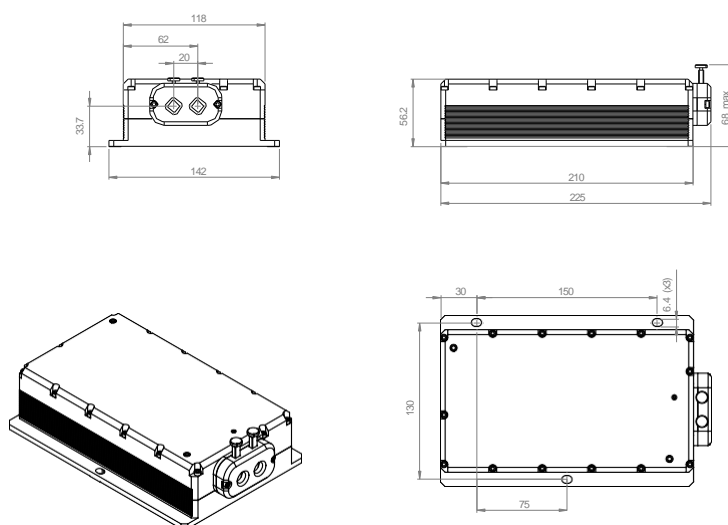

MPL15100 laser head dimensions with attached harmonics unit (in mm)