

VARIUS™ OEM SPECTROMETER



STARLINE



The VARIUS™ OEM spectrometer represents the pinnacle of integration-friendly design, offering adaptability for embedding into (OEM) systems. Tailored for industrial applications, this OEM variant of the VARIUS™ stands out with its robust and efficient features.

It withstands harsh conditions, provides reliable and accurate measurements, and enable efficient data integration with other machinery or control systems. Its versatility and adaptability make it well-suited for quality control, process monitoring, and automation applications.

PRODUCT VARIATIONS

To provide our customers with the best possible service, the VARIUS™ spectrometer is available in two product variations.

1. VARIUS™

Available with 2048 or 4096 pixel detector, USB3 high speed data transfer, and a replaceable slit to customize your throughput and resolution.

2. VARIUS™ OEM

Industrial OEM-version with a stainless steel electromagnetic compatible housing. Optimized for integration into your product or system.

WHY THE VARIUS?

- Patented optical bench design
- Flexible performance through replaceable slit
- Versatile spectroscopy design
- Semi-automated production for unsurpassed inter-instrument reproducibility & scalability
- Superior stray light performance
- High signal-to-noise ratio
- Easy to operate with intuitive software
- Cost-effective instrument

APPLICATIONS & INDUSTRIES

The VARIUS™ is optimized for a wide variety of applications and industries. Including, but not limited to;



Agriculture & Food
Leaf measurements
Chlorophyll analysis

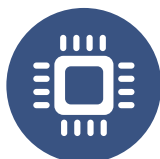

Semiconductor
Thin Film Coating
Coating Deposition



Lighting
Quality Control
Radiometry



Laboratory
Research and
Chemistry labs



System Integration
Integrate into your
product or system

SPECIFICATIONS VARIUS™

Scan the QR-code below for the full specifications of all variants.

	VARIUS™ 2K	VARIUS™ 4K
Optical Bench	Symmetrical Czerny-Turner design, 75 mm focal length; VRS bench	
Wavelength range	190 - 1100 nm	
Stray light	0.1 - 1% (typical value 300 l/mm, blaze 300 nm < 0.3%)	
Detector	HAM S11639, CMOS linear array, 2048 pixels (14x200 µm)	HAM S13496, CMOS linear array, 4096 pixels (7x200 µm)
Signal/Noise	375:1	365:1
Dynamic Range	4500	
Dark noise	15 cnts	
AD converter	16-bit, 6 MHz	
Integration time	9 µs – 30 s	
Interface	USB 3.0 high speed (5Gbps), Gigabit Ethernet (1 Gbps)	
Sample speed on-board averaging	0.38 ms/scan	0.70 ms/scan
Data transfer speed	0.38 ms/scan (USB3.0), 1.0 ms (ETH)	0.70 ms/scan (USB3.0), 1.31 ms (ETH)
Digital I/O	HD-26 connector, 2 Analog in, 2 Analog out, 13 Digital bidirectional, trigger, sync., strobe, laser	
Dimensions, weight	179×110,1×44,8 mm - 799,5 grams	
Power supply	Default USB3 power, 500 mA or 12 VDC, 300 mA	
Temperature range	5-55 °C	

DIMENSIONS

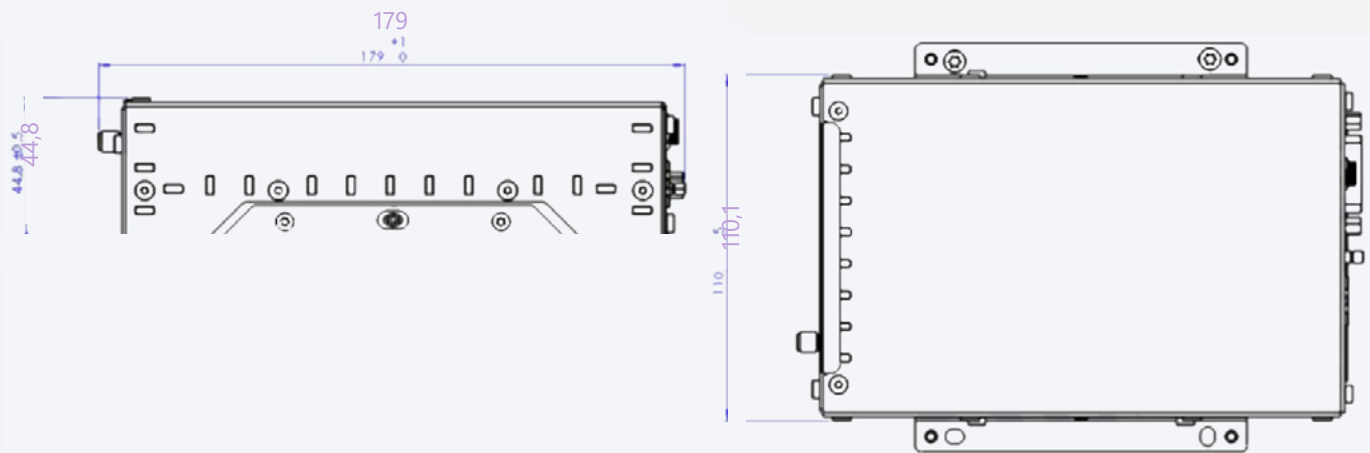

Dimensions in mm



FULL PRODUCT OVERVIEW & SPECIFICATIONS

Scan the QR-code for the full product specifications, grating options, ordering options, and more. Discover the flexibility of the VARIUS™ and find your ideal variation.