

Narrow-Bandwidth Optical Parametric Amplifier



Picosecond pulses from a femtosecond pump

210 – 4800 nm tuning range

800 fs – 3 ps pulse duration

< 20 cm^{-1} spectral bandwidth

Up to 100 kHz repetition rate

High output stability

ORPHEUS-PS tuning curves
Pump: 5 W, 1000 μJ , 5 kHz from PHAROS-SP

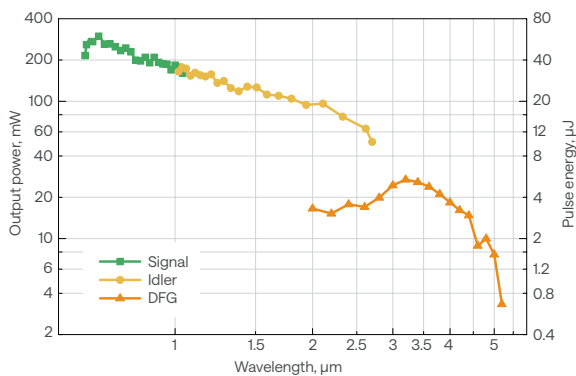

Drawings

ORPHEUS-PS drawings

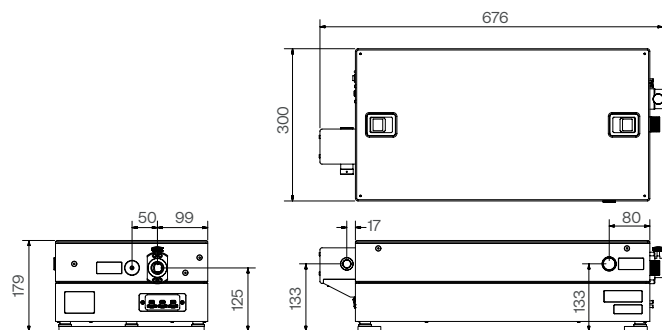

ORPHEUS-PS with SHBC drawing

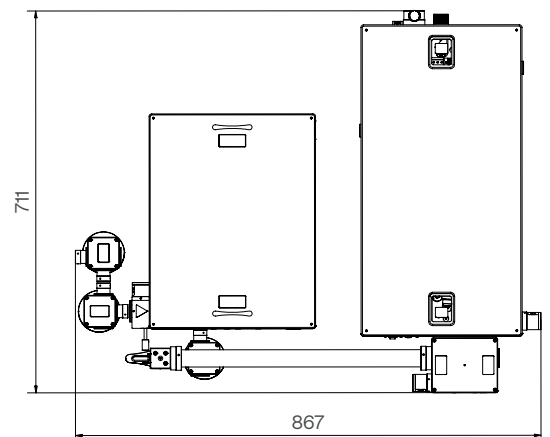

Specifications

MAIN OUTPUT

Tuning range ¹⁾	640 – 1000 nm (signal) 1060 – 2600 nm (idler)
Conversion efficiency	> 6% @ 700 nm
Pulse duration	800 fs – 3 ps
Spectral bandwidth	< 20 cm ⁻¹ @ 700 – 2000 nm
Pulse-to-pulse energy stability ²⁾	< 2% @ 800 nm

AUXILIARY OUTPUT 1 (515 nm)

Center wavelength ³⁾	515 nm ± 5 nm
Generation efficiency ⁴⁾	> 15%

AUXILIARY OUTPUT 2 (1030 nm)

Center wavelength ⁵⁾	1030 ± 10 nm
Pulse duration	< 300 fs
Pulse energy	> 5 μJ

WAVELENGTH EXTENSION

SH package 320 – 500 nm (SHS), 530 – 640 nm (SHI)	> 3% @ 350 nm
FH package 210 – 250 nm (FHS), 265 – 320 nm (FHI)	> 0.3% @ 230 nm
2400 – 4800 nm (DFG)	> 0.25% @ 3200 nm ⁶⁾

PUMP LASER REQUIREMENTS

Pump laser ⁷⁾	PHAROS or CARBIDE with uncompressed output option
Center wavelength	1030 ± 10 nm
Repetition rate	Single-shot – 100 kHz
Maximum pump power	20 W
Pump pulse energy	100 μJ – 3.2 mJ

ENVIRONMENTAL & UTILITY REQUIREMENTS

Operating temperature ⁸⁾	19 – 25 °C (air conditioning recommended)
Relative humidity ⁸⁾	20 – 70% (non-condensing)
Electrical requirements	100 – 240 V AC, 1.4 A; 50 – 60 Hz
Rated power	120 W
Power consumption	Standby: 10 W Max during wavelength tuning: 100 W

¹⁾ For single wavelength (515 nm) picosecond output, refer to SHBC.

²⁾ Expressed as NRMSD (normalized root mean squared deviation).

³⁾ Direct SHBC output, not simultaneous to OPA; see details in SHBC specifications.

⁴⁾ Specified as percentage of pump pulse energy.

⁵⁾ Compressed pump output.

⁶⁾ For > 200 μJ pump pulse energy.

⁷⁾ The pump laser is first paired with the SHBC module, then the SHBC output is used to pump the OPA. The parameter requirements are for the pump laser.

⁸⁾ Specifications are guaranteed for a maximum temperature variation of ± 1 °C and humidity variation of ± 10%.

